

Sandro La Ferla backdrops

sandrolaferla@icloud.com / 80 Nassau St., New York, NY 10038 / 646-490-4820

www.sandrolaferlabackdrops.com

Shipping Warehouse - 183 Lorraine Street, Brooklyn, NY 11231

Backdrop Setup Instructions Sweep

You have made an excellent choice. Our sweep backdrop will give you the advantage of shooting a full figure with an uninterrupted background. A sweep is often used for abstracts but we also have created a number of realistic scenes which allow you to set the model right 'in the picture'; no need for additional foreground.

The backdrop comes rolled on a 10' or 12' cardboard tube. A standard size sweep is 20' high (or long) by 10' or 12' wide.

We designed it to be set up like a roll of seamless paper. It's easy. Just slip an aluminum crossbar through the cardboard tube and unroll.

The backdrop is taped and stapled to the cardboard tube. Please do not remove the fastening.

We designed the lower portion of the backdrop, about 10 feet, to be walked on but, do not step on the upper portion of the backdrop. Masking tape on the soles of shoes will protect the canvas. Please be careful not to spill oils or other materials that will damage the canvas.

Painted canvas is more flexible than your seamless paper but it will still crease if not handled gently.

Do not crumple, fold or crease. We want to avoid damages. If you need help please call us.

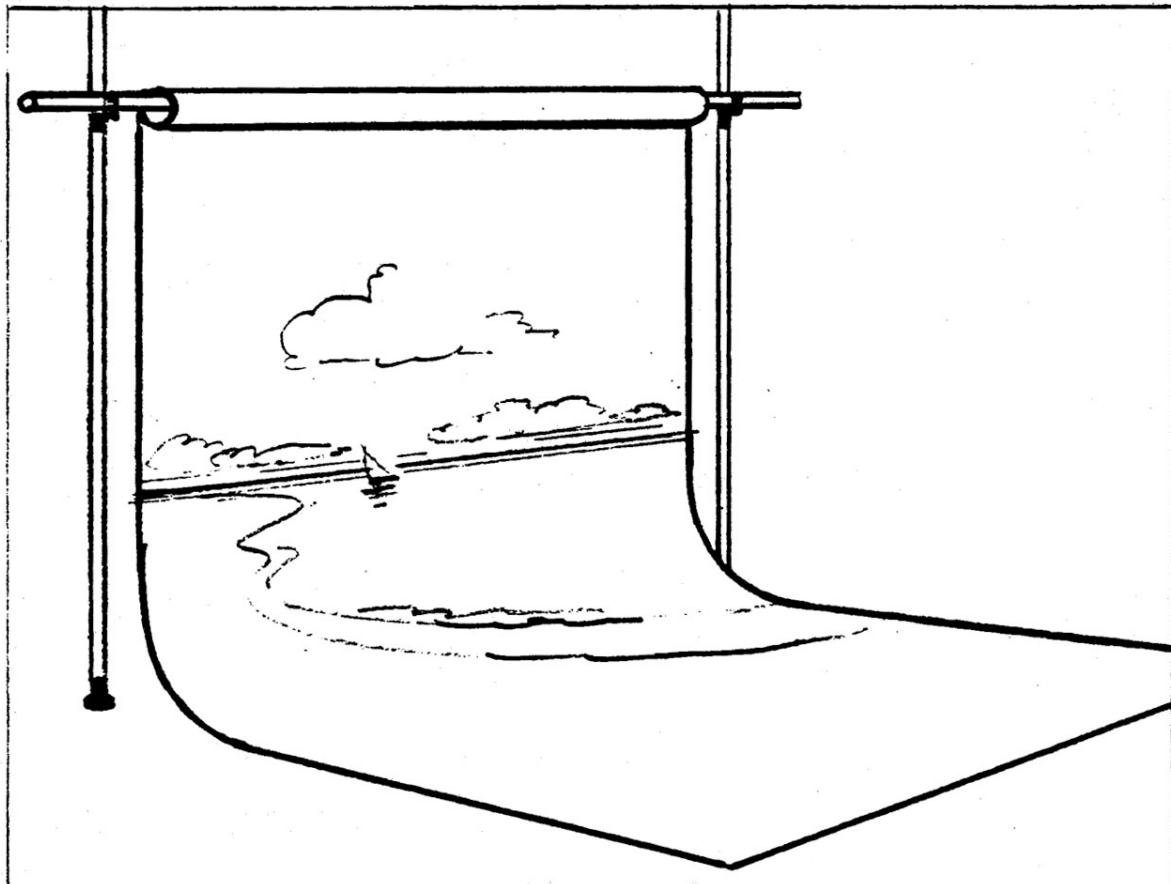

Sandro La Ferla backdrops

sandrolaferla@icloud.com / 80 Nassau St., New York, NY 10038 / 646-490-4820

www.sandrolaferlabackdrops.com

Shipping Warehouse - 183 Lorraine Street, Brooklyn, NY 11231

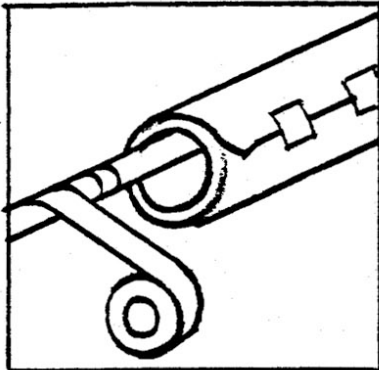

1. Setting up: slip an aluminum crossbar through the cardboard tube. If necessary add an extension and reinforce with tape.

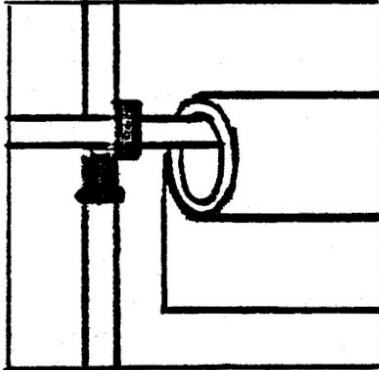

2. Set up two polecats and the crossbar. The backdrop's end is securely fastened to its tube. Please do not remove this fastening.

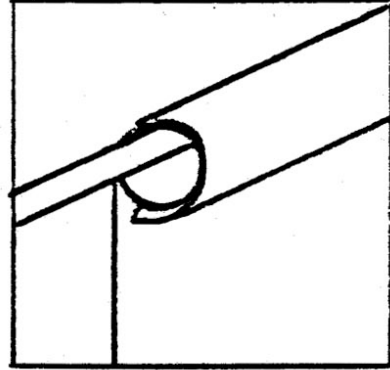

3. Control the unrolling of the canvas. Leave one turn of canvas around the end for extra safety.

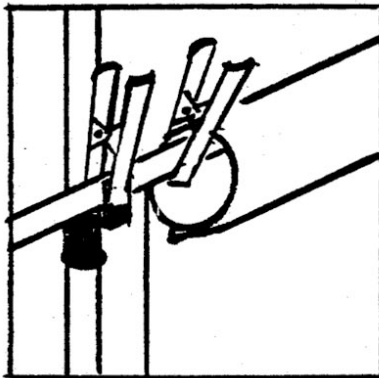

4. Clamp cardboard tube to aluminum crossbar and clamp crossbar to its hooks so that it will not turn.

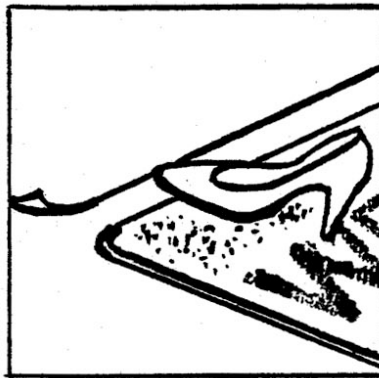

5. Wipe shoes clean on a mat before stepping on the lower portion of the backdrop. Cover canvas with paper for preparatory work.

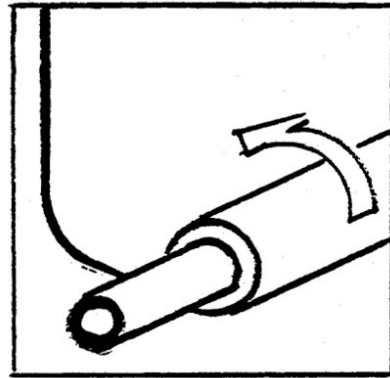

6. If bottom of backdrop is not used, tape the edge temporarily to a seamless and roll back. This will avoid folds and creases.

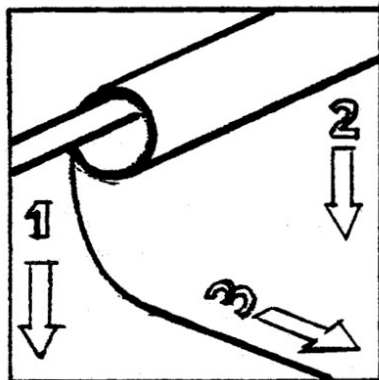

7. Taking down: Two persons lower the cardboard tube to the floor while a third pulls the bottom edge. Do not crease. Do not drape.

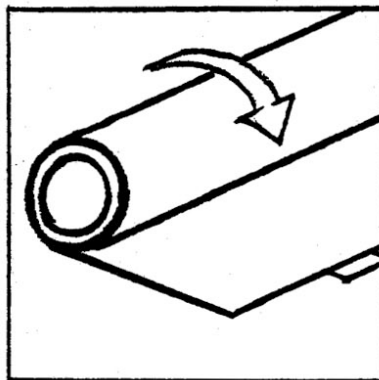

8. When backdrop is flat on the floor, reroll tightly. Tape backdrop shut and return it to its shipping bag.

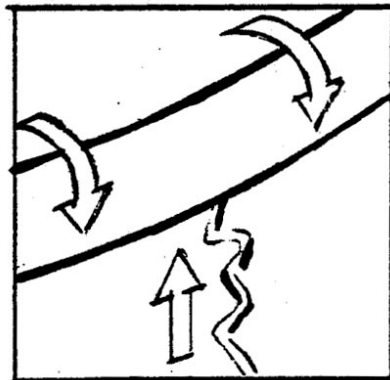

9. Only if you do not have floor space and must reroll backdrop standing up; support the middle while rerolling or weight of canvas will create a wrinkle.